

model Garden^{cart}

TOTAL CAPACITY	19,400 in ³	317 L
BASKET CAPACITY - UPPER		
BASKET CAPACITY - LOWER		
BASKET CAPACITY - REAR	1,040 in ³	17 L
LOWER TRAY CAPACITY	18,360 in ³	300 L
LOWER TRAY CAPACITY - REAR		
NESTING DISTANCE	11.42"	290 mm
WEIGHT	84.7 lbs	38.5 kg
STANDARD FEATURES	E-Coat + Powder Coat Snap Down Handle Bumpers 5" Polyurethane Wheels	

AVAILABLE FEATURES	Custom Colours Custom Finishes Cart Locks Anti-Static Wheel Cup Holder	Bag Hook Scanner Holder Cart Containment Components (Factory Installed)
--------------------	--	--



5181 Everest Drive Mississauga, Ontario L4W 2R2
 1.888.473.3629 | www.instorecorp.com

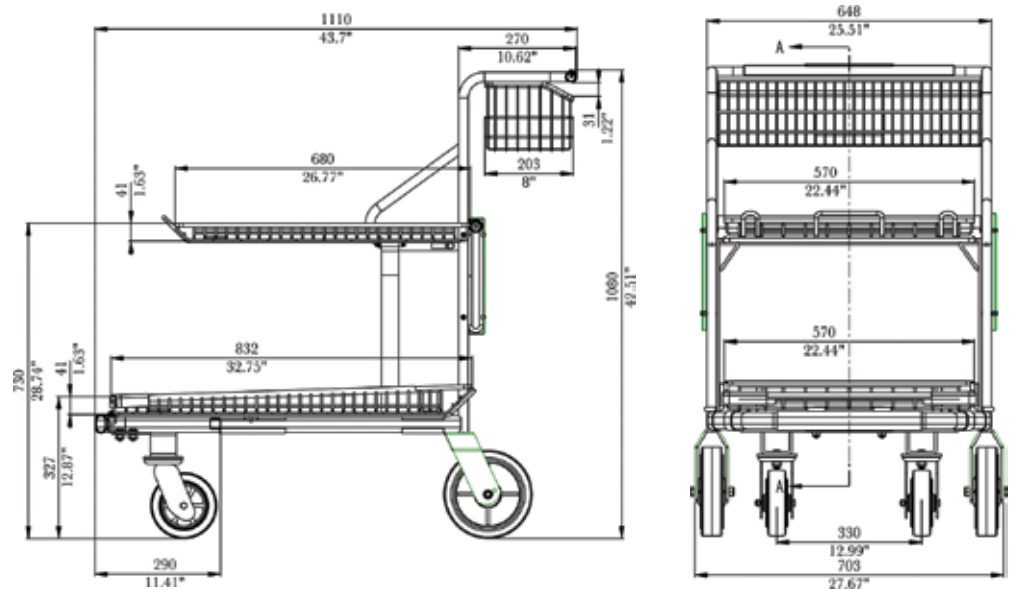

*Dimensions (inches/mm)