

model

IS1

TOTAL CAPACITY	9,058 in <sup>3</sup>	148 L
BASKET CAPACITY - UPPER	2,448 in <sup>3</sup>	40 L
BASKET CAPACITY - LOWER		
BASKET CAPACITY - REAR	490 in <sup>3</sup>	8 L
LOWER TRAY CAPACITY	6,120 in <sup>3</sup>	100 L
LOWER TRAY CAPACITY - REAR		
NESTING DISTANCE	6.77"	172 mm
WEIGHT	46.2 lbs	21.0 kg
STANDARD FEATURES	E-Coat + Powder Coat 1" round handle Bumpers 5" Polyurethane wheels	

AVAILABLE FEATURES	Custom Colours	Cup/Floral Holder
	Custom Finishes	Bag Hook
	Cart Locks	Scanner Holder
	Anti-Static Wheel	Cart Containment Components (Factory Installed)
	Ergonomic Handle	



5181 Everest Drive Mississauga, Ontario L4W 2R2  
 1.888.473.3629 | www.instorecorp.com

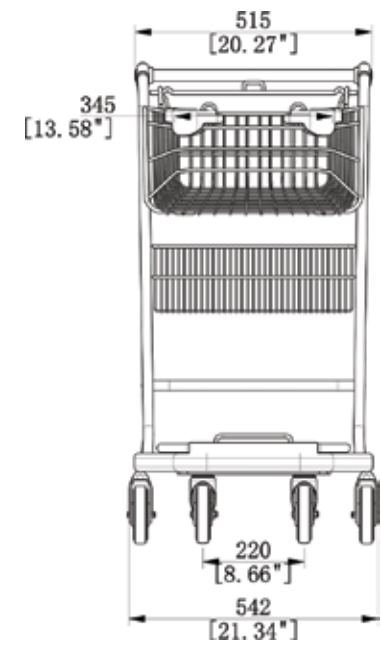
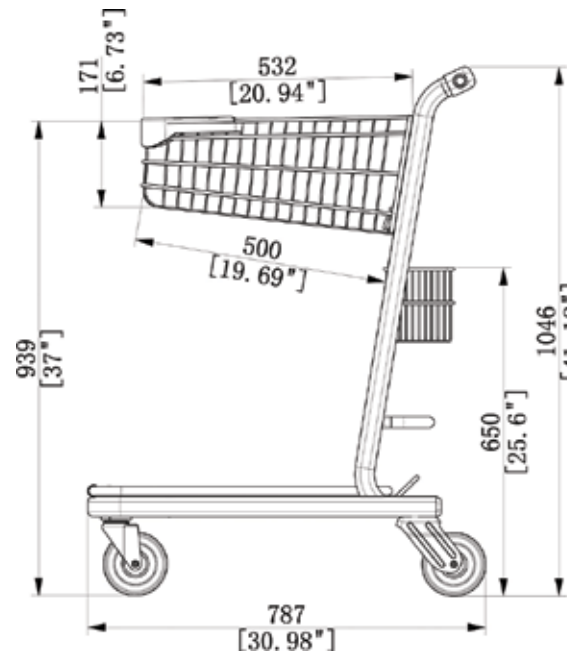

\*Dimensions (inches/mm)