

model

PFLOW  
**OX5**

TOTAL CAPACITY	15,300 in <sup>3</sup>	250 L
BASKET CAPACITY - UPPER	11,016 in <sup>3</sup>	180 L
BASKET CAPACITY - LOWER		
BASKET CAPACITY - REAR		
LOWER TRAY CAPACITY	4,284 in <sup>3</sup>	70 L
LOWER TRAY CAPACITY - REAR		
NESTING DISTANCE	13.9"	353 mm
WEIGHT	68.7 lbs	32.2 kg
STANDARD FEATURES	E-Coat + Powder Coat 1" round handle Bumpers 5" Polyurethane wheels ASTM approved Nylon Seatbelt Pflow Towbar	

AVAILABLE FEATURES	Custom Colours	Cup/Floral Holder
	Custom Finishes	Bag Hook
	Cart Locks	Scanner Holder
	Anti-Static Wheel	Cart Containment Components (Factory Installed)
	Ergonomic Handle	
	Custom Leg hole covers	



5181 Everest Drive Mississauga, Ontario L4W 2R2  
1.888.473.3629 | www.instorecorp.com

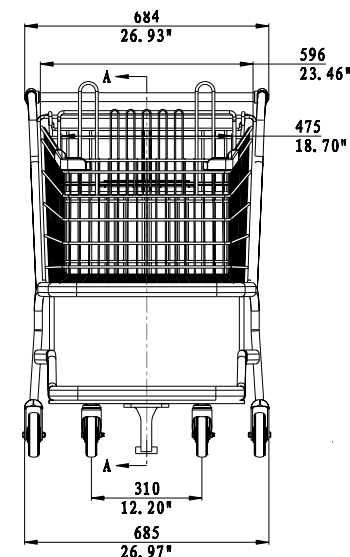
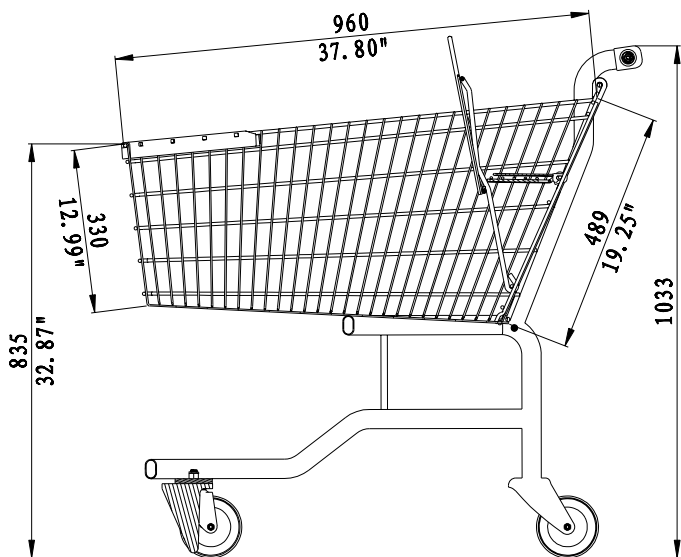

\*Dimensions (mm)