

model X8

| | | |
|----------------------------|--|---------|
| TOTAL CAPACITY | 15,606 in ³ | 255 L |
| BASKET CAPACITY - UPPER | 11,628 in ³ | 190 L |
| BASKET CAPACITY - LOWER | | |
| BASKET CAPACITY - REAR | | |
| LOWER TRAY CAPACITY | 3,978 in ³ | 65 L |
| LOWER TRAY CAPACITY - REAR | | |
| NESTING DISTANCE | 10.63" | 270 mm |
| WEIGHT | 62.3 lbs | 31.9 kg |
| STANDARD FEATURES | E-Coat + Powder Coat 1" round handle Bumpers 5" Polyurethane wheels ASTM approved Nylon Seatbelt | |

| | | |
|--------------------|------------------------|---|
| AVAILABLE FEATURES | Custom Colours | Cup/Floral Holder |
| | Custom Finishes | Bag Hook |
| | Cart Locks | Scanner Holder |
| | Anti-Static Wheel | Cart Containment Components (Factory Installed) |
| | Ergonomic Handle | |
| | Custom Leg hole covers | |



5181 Everest Drive Mississauga, Ontario L4W 2R2
 1.888.473.3629 | www.instorecorp.com

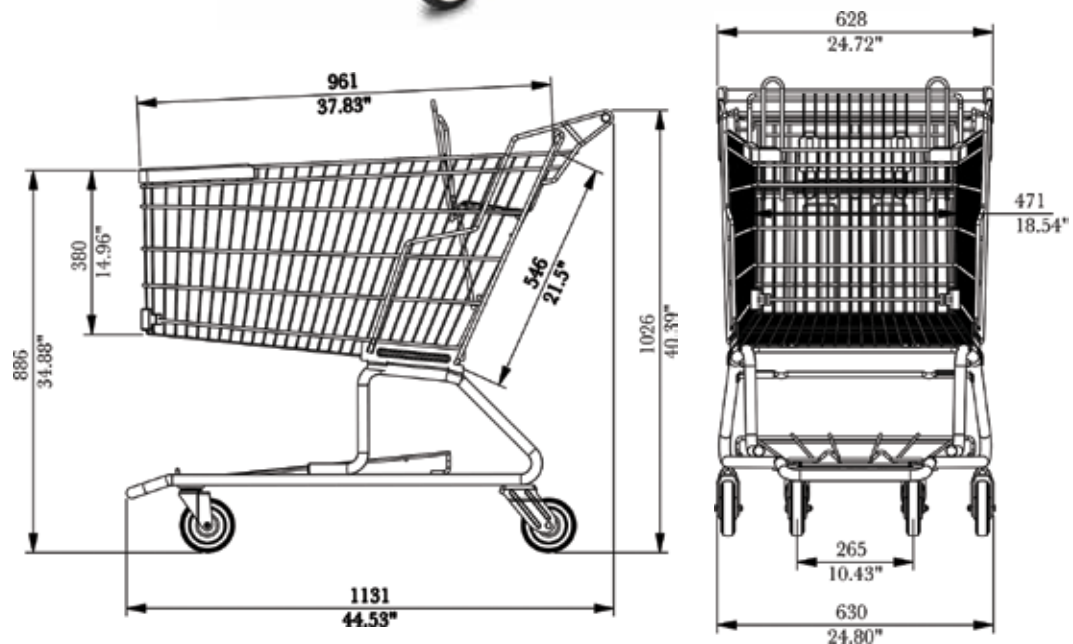

*Dimensions (inches/mm)